

FMD

刃长 FLUTE LENGTH
DR12
顶角 POINT ANGLE
130°
刀柄 SHANK
Φ3.175 h4

REGULAR
标准

QFD
ENGINEERING DRILL®

QFD 工程微钻头®

超微粒子超硬合金钻头 ΦD: 0.020~0.095
Made of only micro-grain carbide

超硬一体型钻头减少了芯摆影响。
使得高精度微细钻孔加工成为可能。

Carbide One-piece drill reduce run-out on drilling.
Provide high-accuracy drilling.

负公差
Minus Tolerance

ENGINEERING DRILL® Type-①

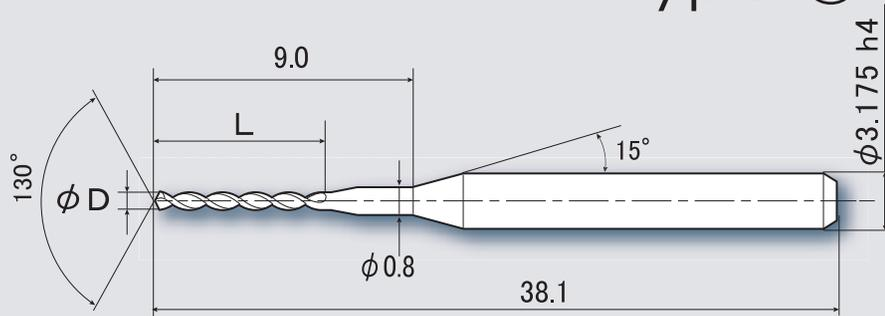

ΦD 公差: +0, -0.003mm
ΦD Tolerance

刃径 φD	型号 Description	刃长 L	形状 Type	定价 JPY Unit price JPY
0.020	QFD-0020-MN0.25	0.25	①	¥20,000
0.025	QFD-0025-MN0.30	0.30	①	¥15,600
0.030	QFD-0030-MN0.35	0.35	①	¥14,400
0.035	QFD-0035-MN0.40	0.40	①	¥13,000
0.040	QFD-0040-MN0.50	0.50	①	¥12,600
0.045	QFD-0045-MN0.55	0.55	①	¥10,000
0.050	QFD-0050-MN0.60	0.60	①	¥9,130
0.055	QFD-0055-MN0.65	0.65	①	¥8,775
0.060	QFD-0060-MN0.70	0.70	①	¥7,500
0.065	QFD-0065-MN0.75	0.75	①	¥7,500
0.070	QFD-0070-MN0.85	0.85	①	¥7,200
0.075	QFD-0075-MN0.90	0.90	①	¥7,200
0.080	QFD-0080-MN0.96	0.96	①	¥6,000
0.085	QFD-0085-MN1.00	1.00	①	¥6,000
0.090	QFD-0090-MN1.10	1.10	①	¥5,600
0.095	QFD-0095-MN1.10	1.10	①	¥5,600

FMD

QFD
ENGINEERING DRILL®



QFD 工程微钻头®

超微粒子超硬合金钻头 ΦD: 0.020~0.390
Made of only micro-grain carbide

超硬一体型钻头减少了芯摆影响。
使得高精度微细钻孔加工成为可能。

Carbide One-piece drill reduce run-out on drilling.
Provide high-accuracy drilling.

正公差
Plus Tolerance

ENGINEERING DRILL® Type-①

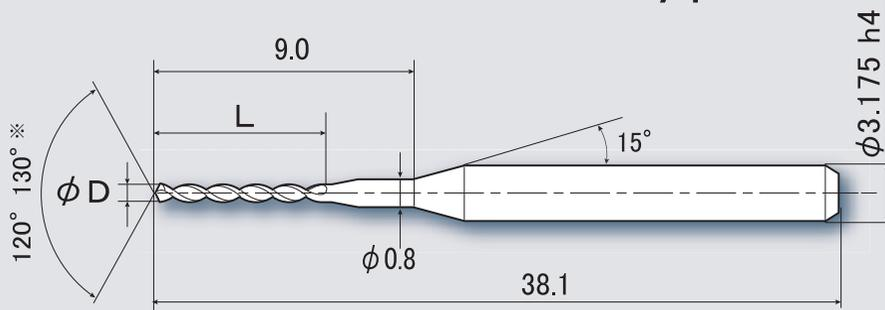

φD 公差: +0.003, -0mm
φD Tolerance

※φ0.10 小于

刃径 φD	型号 Description	刃长 L	形状 Type	定价 JPY Unit price JPY
0.020	QFD-0020-PN0.25	0.25	①	¥20,000
0.025	QFD-0025-PN0.30	0.30	①	¥15,600
0.030	QFD-0030-PN0.35	0.35	①	¥14,400
0.035	QFD-0035-PN0.40	0.40	①	¥13,000
0.040	QFD-0040-PN0.50	0.50	①	¥12,600
0.045	QFD-0045-PN0.55	0.55	①	¥10,000
0.050	QFD-0050-PN0.60	0.60	①	¥9,130
0.055	QFD-0055-PN0.65	0.65	①	¥8,775
0.060	QFD-0060-PN0.70	0.70	①	¥7,500
0.065	QFD-0065-PN0.75	0.75	①	¥7,500
0.070	QFD-0070-PN0.85	0.85	①	¥7,200
0.075	QFD-0075-PN0.90	0.90	①	¥7,200
0.080	QFD-0080-PN0.96	0.96	①	¥6,000
0.085	QFD-0085-PN1.00	1.00	①	¥6,000
0.090	QFD-0090-PN1.10	1.10	①	¥5,600
0.095	QFD-0095-PN1.10	1.10	①	¥5,600

0.100	QFD-0100-PN1.20	1.20	①	¥3,250
0.110	QFD-0110-PN1.30	1.30	①	¥3,250
0.120	QFD-0120-PN1.40	1.40	①	¥3,250
0.130	QFD-0130-PN1.60	1.60	①	¥3,250
0.140	QFD-0140-PN1.70	1.70	①	¥3,250
0.150	QFD-0150-PN1.80	1.80	①	¥3,250
0.160	QFD-0160-PN1.90	1.90	①	¥3,250
0.170	QFD-0170-PN2.00	2.00	①	¥3,250
0.180	QFD-0180-PN2.20	2.20	①	¥3,250
0.190	QFD-0190-PN2.30	2.30	①	¥3,250
0.200	QFD-0200-PN2.40	2.40	①	¥3,250

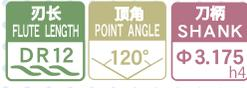

QFD
ENGINEERING DRILL®

QFD 工程微钻头®

超微粒子超硬合金钻头 ΦD: 0.400~0.700
Made of only micro-grain carbide

超硬一体型钻头减少了芯摆影响。
使得高精度微细钻孔加工成为可能。

Carbide One-piece drill reduce run-out on drilling.
Provide high-accuracy drilling.

正公差
Plus Tolerance

ENGINEERING DRILL®
Type-②

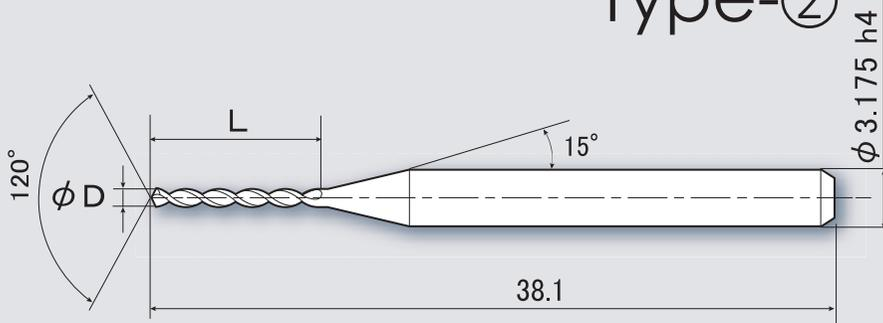

ΦD 公差: +0.003, -0mm
ΦD Tolerance

刃径 φ D	型号 Description	刃长 L	形状 Type	定价 JPY Unit price JPY
0.400	QFD-0400-PN4.80	4.80	②	¥3,250
0.410	QFD-0410-PN4.90	4.90	②	¥3,250
0.420	QFD-0420-PN5.00	5.00	②	¥3,250
0.430	QFD-0430-PN5.20	5.20	②	¥3,250
0.440	QFD-0440-PN5.30	5.30	②	¥3,250
0.450	QFD-0450-PN5.40	5.40	②	¥3,250
0.460	QFD-0460-PN5.50	5.50	②	¥3,250
0.470	QFD-0470-PN5.60	5.60	②	¥3,250
0.480	QFD-0480-PN5.80	5.80	②	¥3,250
0.490	QFD-0490-PN5.90	5.90	②	¥3,250
0.500	QFD-0500-PN6.00	6.00	②	¥3,250
0.510	QFD-0510-PN6.10	6.10	②	¥3,250
0.520	QFD-0520-PN6.20	6.20	②	¥3,250
0.530	QFD-0530-PN6.30	6.30	②	¥3,250
0.540	QFD-0540-PN6.40	6.40	②	¥3,250
0.550	QFD-0550-PN6.60	6.60	②	¥3,250
0.560	QFD-0560-PN6.70	6.70	②	¥3,250
0.570	QFD-0570-PN6.80	6.80	②	¥3,250
0.580	QFD-0580-PN6.90	6.90	②	¥3,250
0.590	QFD-0590-PN7.00	7.00	②	¥3,250

