

# FMD

刃长 FLUTE LENGTH  
DR6

顶角 POINT ANGLE  
130°

刀柄 SHANK  
Φ3.175  
h4

**SQFD**  
SHORT DRILL

**SHORT**  
短刃长

## SQFD 短刃长微钻头

**超微粒子超硬合金钻头 ΦD:0.020~0.095**  
Made of only micro-grain carbide

超硬一体型钻头减少了芯摆影响。  
使得高精度微细钻孔加工成为可能。

Carbide One-piece drill reduce run-out on drilling.  
Provide high-accuracy drilling.

**负公差**  
Minus Tolerance

### SHORT DRILL Type-①

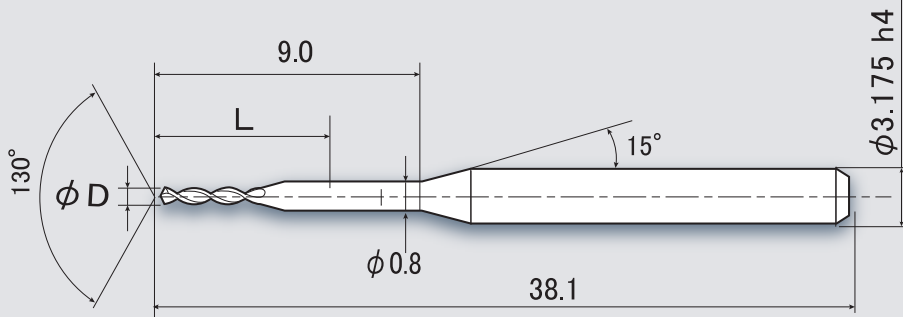

ΦD 公差 : +0, -0.003mm  
ΦD Tolerance

刃径	型号	刃长	形状	定价 JPY
φD	Description	L	Type	Unit price JPY
0.020	SQFD-0020-MN0.12	0.12	①	¥20,000
0.025	SQFD-0025-MN0.15	0.15	①	¥15,600
0.030	SQFD-0030-MN0.18	0.18	①	¥14,400
0.035	SQFD-0035-MN0.21	0.21	①	¥13,000
0.040	SQFD-0040-MN0.24	0.24	①	¥12,600
0.045	SQFD-0045-MN0.27	0.27	①	¥10,000
0.050	SQFD-0050-MN0.30	0.30	①	¥9,130
0.055	SQFD-0055-MN0.33	0.33	①	¥8,775
0.060	SQFD-0060-MN0.36	0.36	①	¥7,500
0.065	SQFD-0065-MN0.39	0.39	①	¥7,500
0.070	SQFD-0070-MN0.42	0.42	①	¥7,200
0.075	SQFD-0075-MN0.45	0.45	①	¥7,200
0.080	SQFD-0080-MN0.48	0.48	①	¥6,000
0.085	SQFD-0085-MN0.51	0.51	①	¥6,000
0.090	SQFD-0090-MN0.54	0.54	①	¥5,600
0.095	SQFD-0095-MN0.57	0.57	①	¥5,600



SQFD  
SHORT DRILL

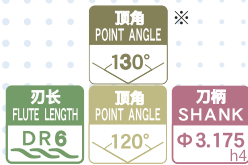

# SQFD 短刃长微钻头

**超微粒子超硬合金钻头**  $\Phi D: 0.020 \sim 0.390$   
Made of only micro-grain carbide

超硬一体型钻头减少了芯摆影响。  
使得高精度微细钻孔加工成为可能。

Carbide One-piece drill reduce run-out on drilling.  
Provide high-accuracy drilling.

**正公差**  
Plus Tolerance

## SHORT DRILL Type-①

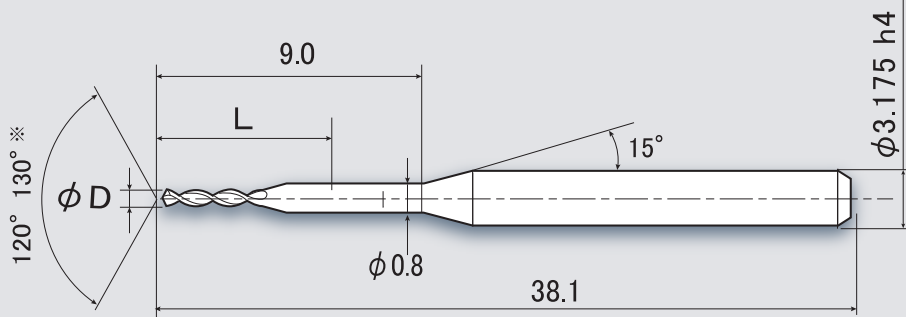

$\Phi D$  公差: +0.003, -0mm  
 $\Phi D$  Tolerance

※ $\Phi 0.10$  小于

刃径	型号	刃长	形状	定价 JPY
$\phi D$	Description	L	Type	Unit price JPY
0.020	SQFD-0020-PN0.12	0.12	①	¥20,000
0.025	SQFD-0025-PN0.15	0.15	①	¥15,600
0.030	SQFD-0030-PN0.18	0.18	①	¥14,400
0.035	SQFD-0035-PN0.21	0.21	①	¥13,000
0.040	SQFD-0040-PN0.24	0.24	①	¥12,600
0.045	SQFD-0045-PN0.27	0.27	①	¥10,000
0.050	SQFD-0050-PN0.30	0.30	①	¥9,130
0.055	SQFD-0055-PN0.33	0.33	①	¥8,775
0.060	SQFD-0060-PN0.36	0.36	①	¥7,500
0.065	SQFD-0065-PN0.39	0.39	①	¥7,500
0.070	SQFD-0070-PN0.42	0.42	①	¥7,200
0.075	SQFD-0075-PN0.45	0.45	①	¥7,200
0.080	SQFD-0080-PN0.48	0.48	①	¥6,000
0.085	SQFD-0085-PN0.51	0.51	①	¥6,000
0.090	SQFD-0090-PN0.54	0.54	①	¥5,600
0.095	SQFD-0095-PN0.57	0.57	①	¥5,600

0.100	SQFD-0100-PN0.60	0.60	①	¥3,250
0.110	SQFD-0110-PN0.66	0.66	①	¥3,250
0.120	SQFD-0120-PN0.72	0.72	①	¥3,250
0.130	SQFD-0130-PN0.78	0.78	①	¥3,250
0.140	SQFD-0140-PN0.84	0.84	①	¥3,250
0.150	SQFD-0150-PN0.90	0.90	①	¥3,250
0.160	SQFD-0160-PN0.96	0.96	①	¥3,250
0.170	SQFD-0170-PN1.02	1.02	①	¥3,250
0.180	SQFD-0180-PN1.08	1.08	①	¥3,250
0.190	SQFD-0190-PN1.14	1.14	①	¥3,250

刃径	型号	刃长	形状	定价 JPY
φ D	Description	L	Type	Unit price JPY
0.200	SQFD-0200-PN1.20	1.20	①	¥3,250
0.210	SQFD-0210-PN1.26	1.26	①	¥3,250
0.220	SQFD-0220-PN1.32	1.32	①	¥3,250
0.230	SQFD-0230-PN1.38	1.38	①	¥3,250
0.240	SQFD-0240-PN1.44	1.44	①	¥3,250
0.250	SQFD-0250-PN1.50	1.50	①	¥3,250
0.260	SQFD-0260-PN1.56	1.56	①	¥3,250
0.270	SQFD-0270-PN1.62	1.62	①	¥3,250
0.280	SQFD-0280-PN1.68	1.68	①	¥3,250
0.290	SQFD-0290-PN1.74	1.74	①	¥3,250
0.300	SQFD-0300-PN1.80	1.80	①	¥3,250
0.310	SQFD-0310-PN1.86	1.86	①	¥3,250
0.320	SQFD-0320-PN1.92	1.92	①	¥3,250
0.330	SQFD-0330-PN1.98	1.98	①	¥3,250
0.340	SQFD-0340-PN2.04	2.04	①	¥3,250
0.350	SQFD-0350-PN2.10	2.10	①	¥3,250
0.360	SQFD-0360-PN2.16	2.16	①	¥3,250
0.370	SQFD-0370-PN2.22	2.22	①	¥3,250
0.380	SQFD-0380-PN2.28	2.28	①	¥3,250
0.390	SQFD-0390-PN2.34	2.34	①	¥3,250

## MEMO

# FMD

刃长 FLUTE LENGTH  
DR6  
顶角 POINT ANGLE  
120°  
刀柄 SHANK  
Φ3.175  
h4

**SQFD**  
SHORT DRILL

**SHORT**  
短刃长

## SQFD 短刃长微钻头

**超微粒子超硬合金钻头 ΦD: 0.400~0.500**  
Made of only micro-grain carbide

超硬一体型钻头减少了芯摆影响。  
使得高精度微细钻孔加工成为可能。

Carbide One-piece drill reduce run-out on drilling.  
Provide high-accuracy drilling.

**正公差**  
Plus Tolerance

### SHORT DRILL Type-②

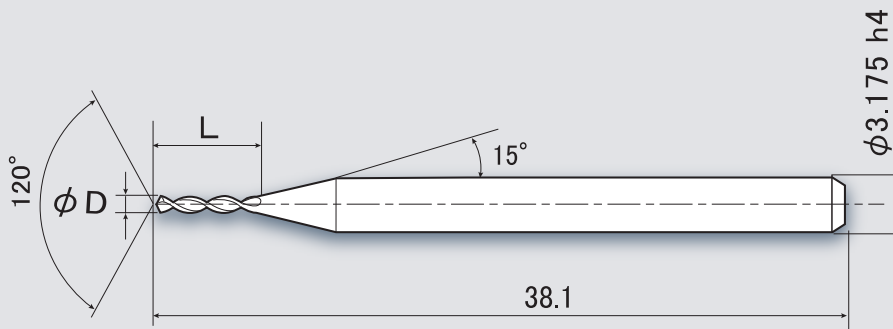

ΦD 公差 : +0.003, -0mm  
ΦD Tolerance

刃径	型号	刃长	形状	定价 JPY
φ D	Description	L	Type	Unit price JPY
0.400	SQFD-0400-PN2.40	2.40	②	¥3,250
0.410	SQFD-0410-PN2.46	2.46	②	¥3,250
0.420	SQFD-0420-PN2.52	2.52	②	¥3,250
0.430	SQFD-0430-PN2.58	2.58	②	¥3,250
0.440	SQFD-0440-PN2.64	2.64	②	¥3,250
0.450	SQFD-0450-PN2.70	2.70	②	¥3,250
0.460	SQFD-0460-PN2.76	2.76	②	¥3,250
0.470	SQFD-0470-PN2.82	2.82	②	¥3,250
0.480	SQFD-0480-PN2.88	2.88	②	¥3,250
0.490	SQFD-0490-PN2.94	2.94	②	¥3,250
0.500	SQFD-0500-PN3.00	3.00	②	¥3,250

高精度微细钻头  
HIGH ACCURACY DRILL

高精度微细钻头  
HIGH ACCURACY DRILL